

# 125MHz Digitizer Firmware Description

Version: ABC02 (For PXIE Toroids and Ring Pickups)

---

*This first page contains notes about what's new in this particular version, the rest of the documentation will be kept up to date to my best knowledge.*

Software Initialization Instructions are in Chapter 10 on page 12 (followed by the complete register map.)

Starting on page 5 are some illustrations of the different running modes to accommodate different beam operations and could be helpful for understanding the firmware.

Some main changes:

1. Run modes are reorganized to accommodate short pulse, long pulse and CW mode. Integration values can be sent out at a programmable rate. (1kHz was initially suggested.) Register setting combinations are provided here.
2. Since with multiple integration windows the chopper gate is no longer enough to calculate the Average Beam Current. Firmware does it now. Readout registers are provided.
3. Machine protection scheme is slightly modified and minor software changes may be needed.
4. Scaling of the readings might have to be re-calculated if we use the Average Beam Current readings directly from the digitizer.

## 1. Hardware overview: the digitizer

6U VME Board, draws 2.5A of current

8 Channel analog input, 14-bit ADC (ADS6445), padded to 16 bits

Cyclone III FPGA, Fmax = 125MSPS

24MB per channel buffer on DDR2 SDRAM (12M samples per channel)

CDCE62005 clock chip / onboard 125MHz oscillator / external clock input

Three (3) digital inputs (programmable) for triggering and gates

One (1) digital output (programmable)



Hardware Block Diagram:

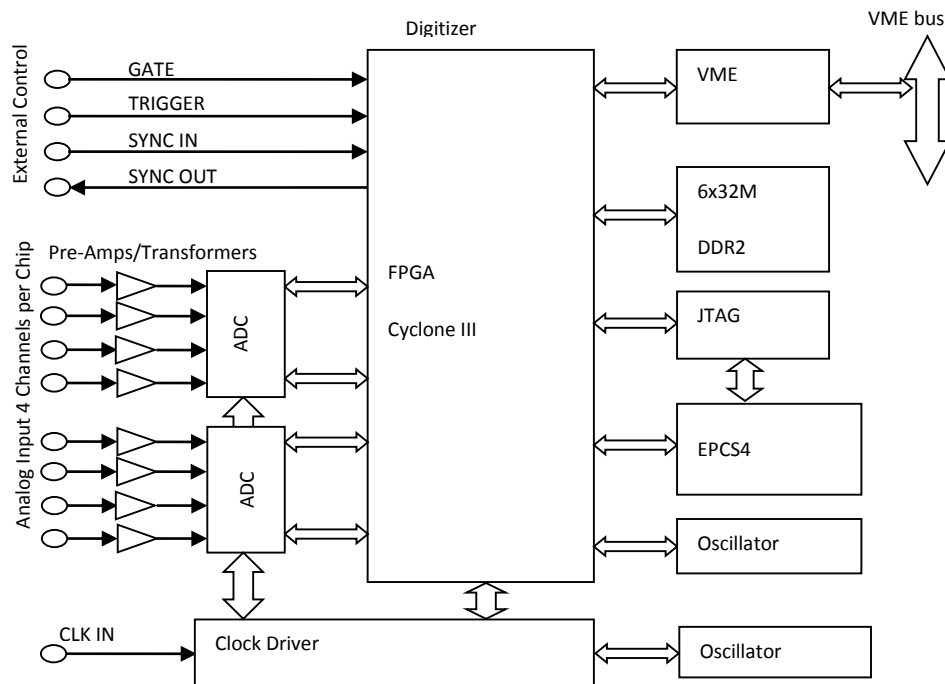

## 2. Firmware Block Diagram

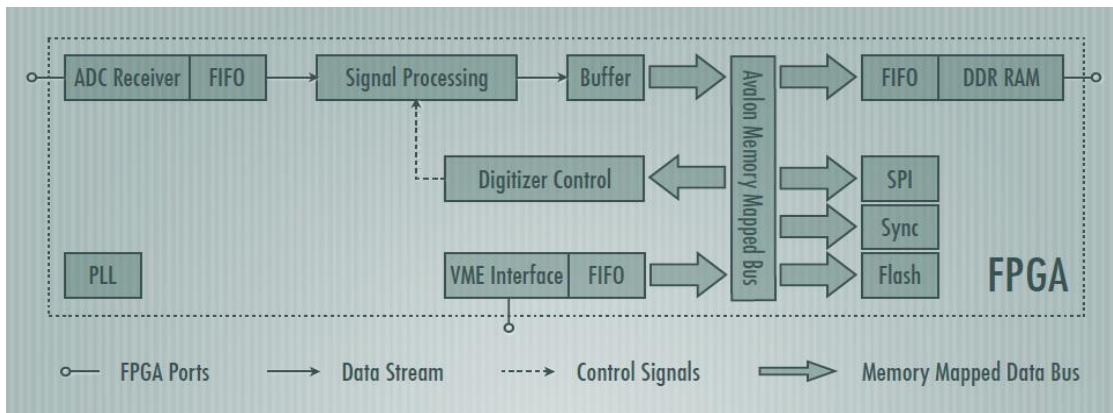

### 3. Address Map

Two sets of data are saved to memory: “Averaged Data” and “Raw Data”

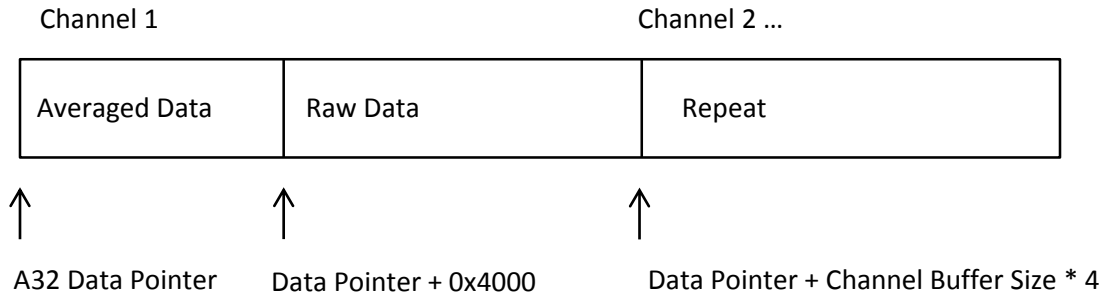

Memory location for Averaged Data = Data Pointer + (CH# - 1) \* Buffer Size \* 4. This part of memory is not used in this design. For example, with default settings, channel 1 starts at 0x8000000, with channel buffer size set at “0x10000”, channel 2 starts at 0x8040000, etc.

Raw ADC data are stored in the channel’s memory block after the Averaged data. Address offset is x4000.

All registers are in A16 address space with an offset set by the Hardware Address Switches. All addresses can be accessed in 8, 16 or 32 bits.

### 4. Signal Processing

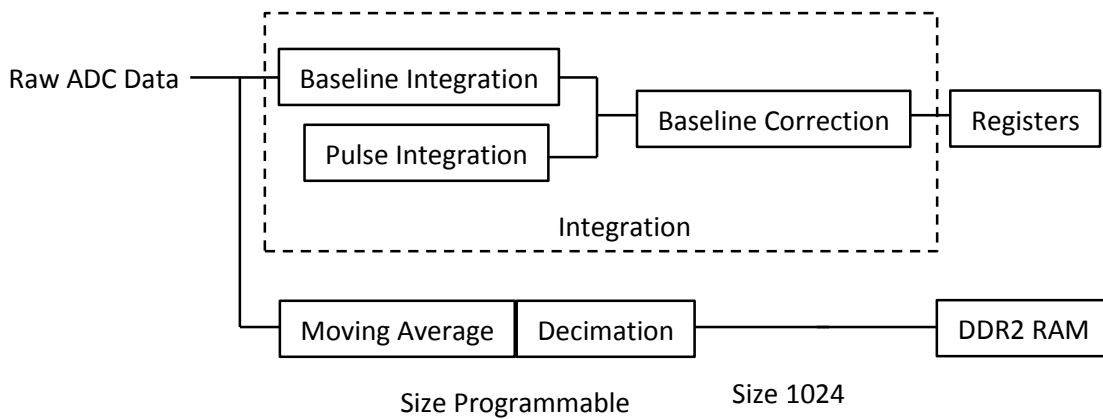

### 5. Moving-Average and Decimation of ADC Data (Averaged Data):

The ADC data is averaged and decimated to reduce data size. The size of the decimation is configured with register 0x2B7, D8.

The number of “averaged data” points to be saved to memory is determined by register 0x2B4, D16.

## 6. Integration of Beam Signal

Same as version ABB, sizes of the integration windows are determined by the product of two registers: "Integration Window Size" and "Window Size Multiplier".

The "Integration Window Size" register determines the size of the baseline correction integration window. Max value is 0x2000 (8192). Integrated Baseline can be averaged "Pulse-Over-Pulse", maximum of 128 pulses, '1' by default.

"Window Size Multiplier" register, 0x2B8, D8, helps determine the window size for pulse integration (this register is 8 bit, unsigned, and max value is 0xFF):

$$\text{Pulse Integration Size} = \text{Integration Window Size} * \text{Window Size Multiplier}$$

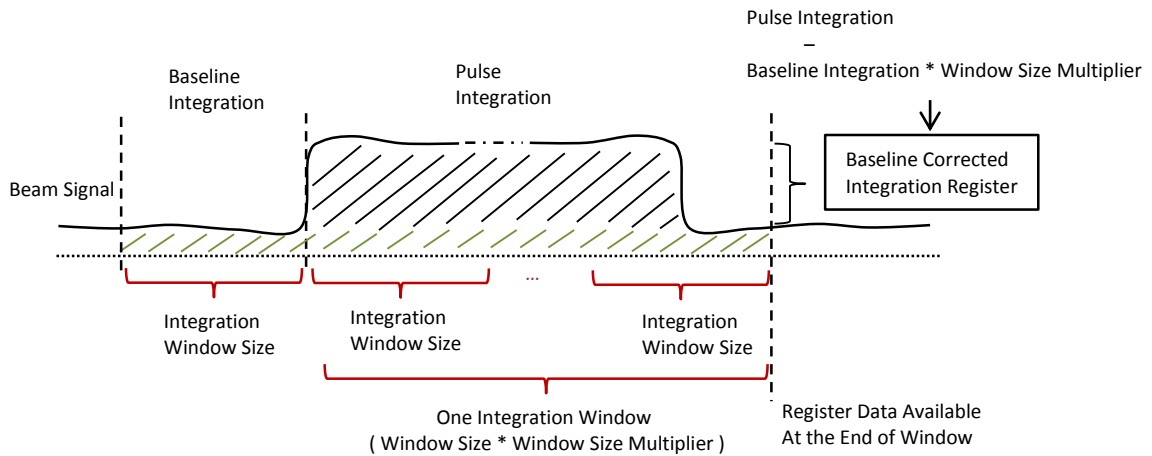

All register values will be available at the time the integration window is finished, and will stay available until the next integration window finishes. In the case of only one integration window, data holds until the digitizer receives the next sync pulse.

## 7. Running Modes

This version supports a few different timing schemes: Single Window Mode for short pulses, Multiple Window Mode for long pulses as well as a Continuous Mode for trigger-less CW mode. The key register for configuring run modes is the Mode Register (0x200, D8), highlighted bits are newly added in this version:

Mode Register (Address: 0x200, D8), note that bits 2-4 are not used.			
Bit#	Name	Description	Default
7	Arm	'1' = Use external 'SYINC' input on the board to arm digitizer, this is the most commonly used mode. '0' = Use software to arm the digitizer.	1
6	Trig	'1' = Use external TRIGGER input to start saving ADC data, not used for PXIE. '0' = Do not use TRIGGER.	0
5	Gate	'1' = When using TRIGGER, take only triggers within GATE.	0
1	Gated Windows	'1' = Use external GATE input to determine number of integration windows to run. '0' = Use "Number of Windows" register to determine number of windows.	0
0	CW Mode	'1' = Overwrites "Gated Windows" and "Number of Windows" register, runs infinite number of windows until this bit is reset.	0

Two other registers that are relevant here:

Name	Address	Description
Number of Windows	0x2BC	Specifies number of integration windows to run.
After-Gate Delay	0x2BE	Specifies number of clock cycles to extend the gate when using "Gated Windows"

To understand how to implement different run modes with these registers, here are a few illustrations:

(a). Single Window Mode:

Register values for this mode:				
Reg.	Addr.	Value	Description	
<b>Mode</b>	0x200	0x80	Sync='1', Gated Windows = '0', CW Mode = '0'	
<b>Window Size</b>	0x2BA	Dynamic	Maximum accepted value: 0x2000	
<b>Window Multiplier</b>	0x2B8	Dynamic	Maximum accepted value: 0xFF	
<b>No. of Windows</b>	0x2BC	1		

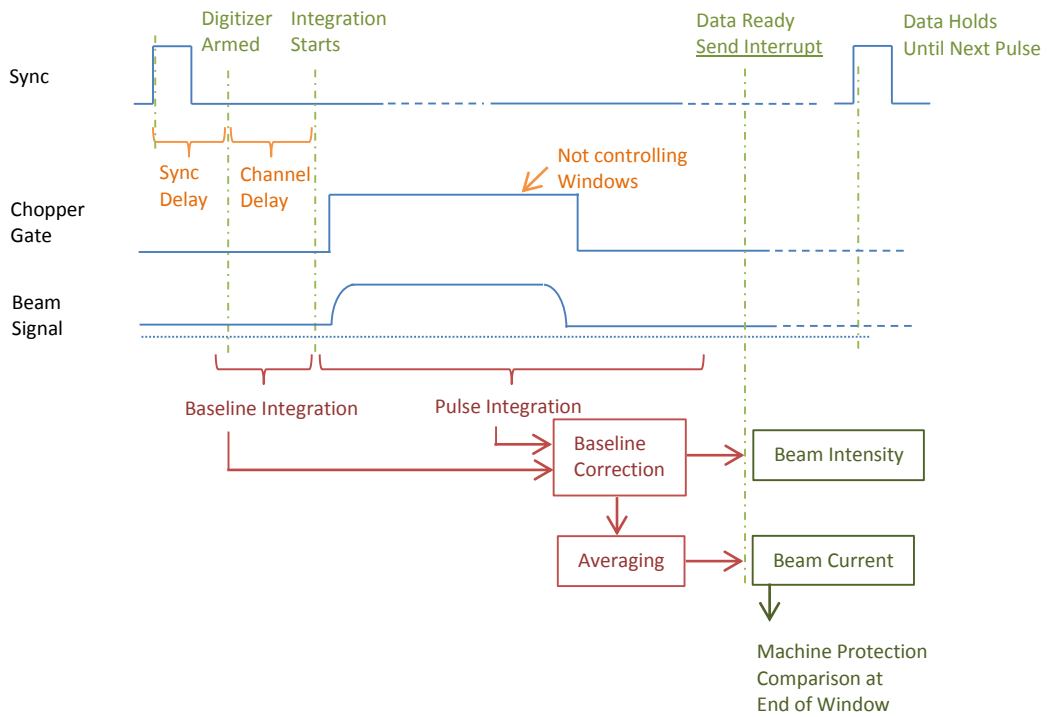

**(b). Multiple Window Mode, Software Set Number of Windows:**

Register values for this mode:			
Reg.	Addr.	Value	Description
Mode	0x200	0x80	Sync='1', Gated Windows = '0', CW Mode = '0'
Window Size	0x2BA	Dynamic	Use 0x186A for 1kHz operation
Window Multiplier	0x2B8	Dynamic	Use 0x14 for 1kHz operation
No. of Windows	0x2BC	Determined by software calculation	

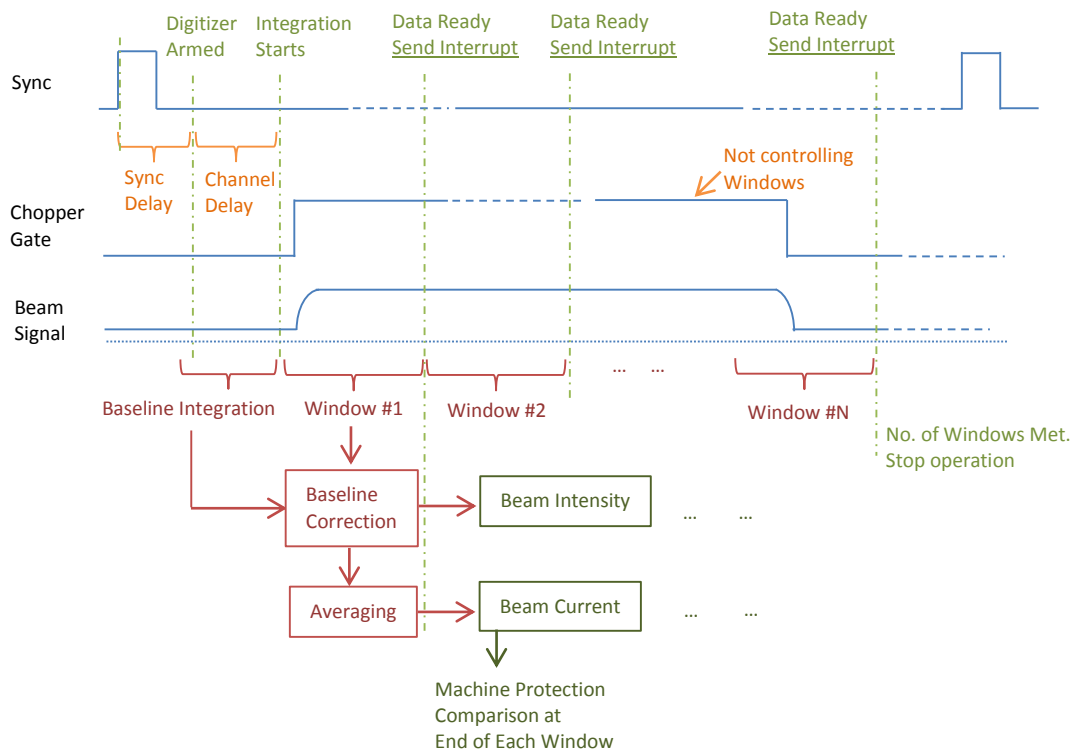

**(c). Multiple Window Mode, Gate Controlled Number of Windows:**

Register values for this mode:				
Reg.	Addr.	Value	Description	
Mode	0x200	0x82	Sync='1', Gated Windows = '1', CW Mode = '0'	
Window Size	0x2BA	Dynamic	Use 0x186A for 1kHz operation	
Window Multiplier	0x2B8	Dynamic	Use 0x14 for 1kHz operation	
No. of Windows	0x2BC	Inactive		

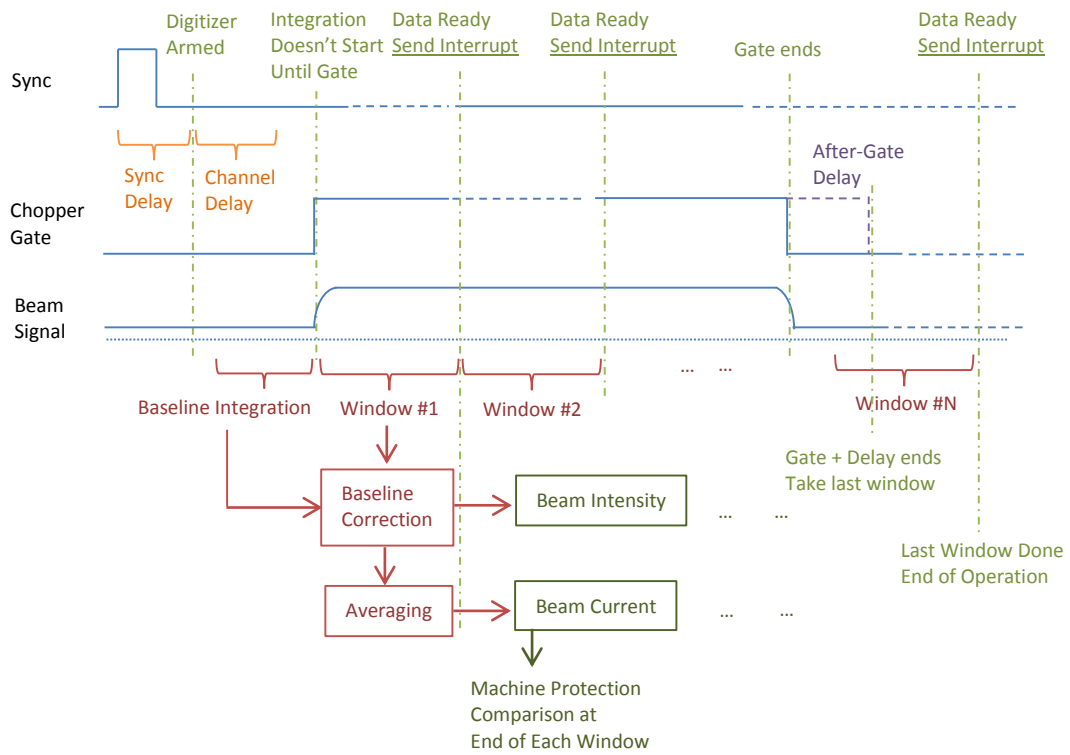



**(d). CW Mode, Software Arm:**

Register values for this mode:				
Reg.	Addr.	Value	Description	
Mode	0x200	0x01	Sync='1', Gated Windows = 'X', CW Mode = '1'	
Window Size	0x2BA	Dynamic	Use 0x186A for 1kHz operation	
Window Multiplier	0x2B8	Dynamic	Use 0x14 for 1kHz operation	
No. of Windows	0x2BC	Inactive		
Software Arm	0x203	0x01	Write '1' to arm digitizer.	

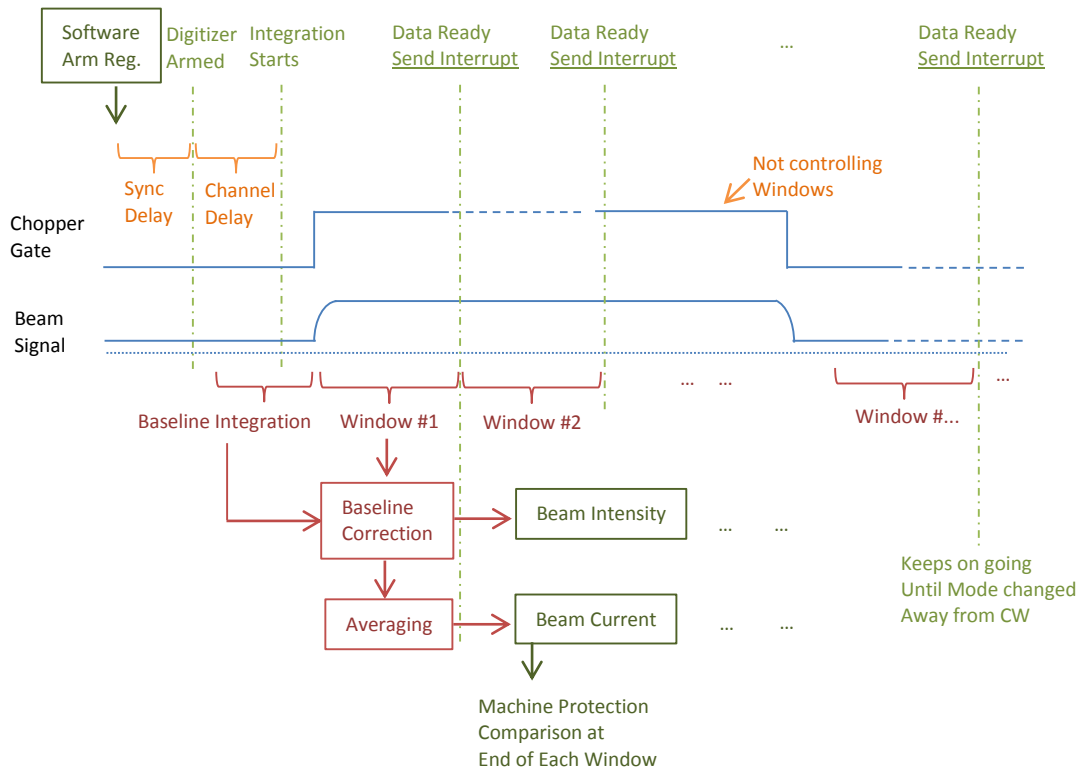

## 8. Averaging of Beam Signals

One new feature on version ABC is that average beam current is also calculated on the firmware. Baseline Corrected Integration value within each window is divided by the total window size.

In the case where part of the integration window happens before beam pulse starts or after it ends, as indicated by the Chopper Gate, beam current is only averaged over the region where Beam Pulse is located inside the window.

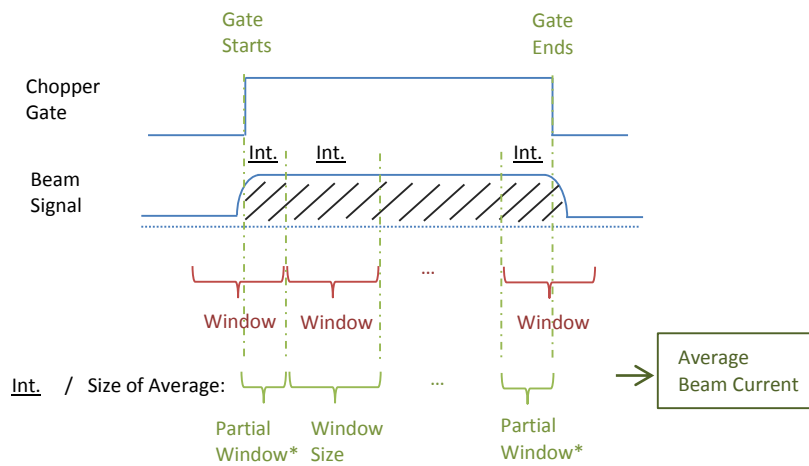

\*: In the case where part of the integration window happens before beam pulse starts or after it ends, as indicated by the Chopper Gate, beam current is only averaged over the region where Beam Pulse is located inside the window.

## 9. Machine Protection Functions

Chopper Gate and Beam Pulse are compared for timing synchronization. If the difference between the rising (or falling) edge of the two signals exceeds a preset margin, digitizer trips.

When enabled, Average Beam Current calculated from each Integration Window is compared to thresholds set by the "Threshold" registers. If it fails the thresholds, the digitizer trips.

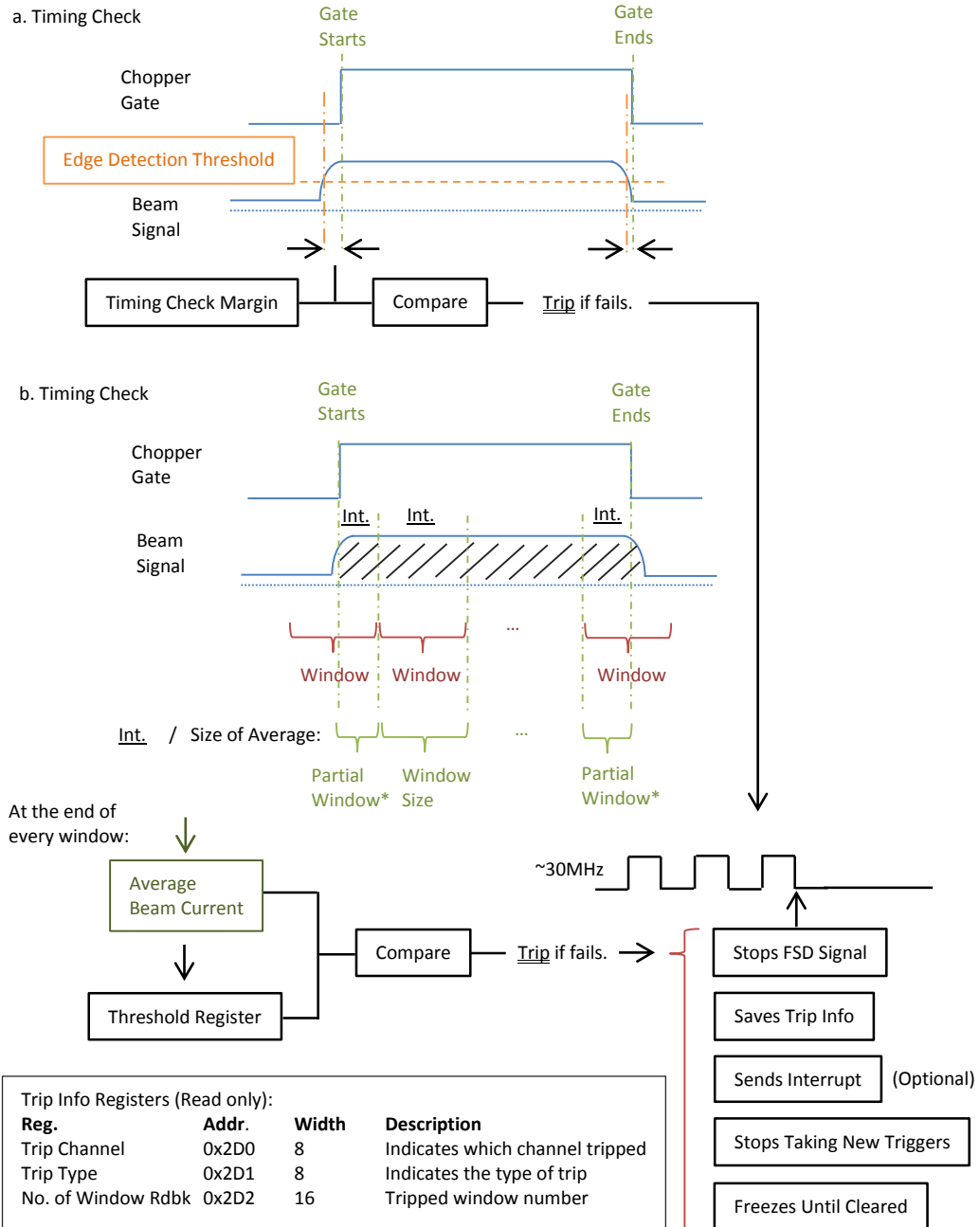

## 10. Software Initialization Instructions

This section assumes settings from version ABB are already in place.

Register Settings for Different Operation Modes:					
Registers	Mode (0x200)	No. Windows (0x2BC)	Window Size (0x2BA)	Window Size Multiplier (0x2B8)	After-Gate Delay (0x2BE)
Short Pulse	0x80	1	Dynamic	Dynamic	NA
Long Pulse	0x80	Calculate?	0x186A	0x14	NA
Long Pulse Using Gate	0x82	NA	0x186A	0x14	0x100
CW Mode	0x81	NA	0x186A	0x14	NA

Note: the "Window Size" values are for 1kHz update rate.

Initialize Clock Registers To These Default Values (125MHz):			
Address	Default Value	Address	Default Value
A0	0x8146002	B4	0x10F00BE
A4	0x8146002	B8	0x04B2030
A8	0x8146000	BC	0xBD0037F
AC	0x6486030	C0	0x20009F5
B0	0x6486031		

Interrupt Related Register Used In This Version:			
Register	Address	Data Width	Description
VME IRQ Mask	0x290	16	Bits <11:0> - Mask for IRQ11 ~ IRQ0. "1" = Active, "0" = Disabled
IRQ Vector for IRQ #1	0x222	16	Data available to read at the end of window.
IRQ Vector for IRQ #2	0x224	16	Machine Protection System Tripped. Optional.

Other Registers: Initialize Registers as Follows (For Ring Pickups):				
Register	Address	D. Width	Initialize:	Create Acnet Device
A32 Data Pointer	0x04	32	You decide.	No.
Channel Buffer Size	0x08	32	0x10000	No.
Number of Raw Samples	0x20C	32	0x2000	No.
Sync Delay	0x2C0	16	0x0	No.
Baseline Average Size	0x3C1	8	0x0	No.
Polarity Flip	0x3C2	8	0xFF	No.

Baseline Correction	0x3C3	8	0xFF	No.
Sync Out select	0x115	8	0xC	No.
Integration Window Size	0x2BA	16	0x2000	See above.
Window Size Multiplier	0x2B8	8	0x4	See above.
Averaged Data Decimation Rate	0x2B7	8	0xA	No.
Averaged Data No. of Samples	0x2B4	16	0x400	No.
Raw Data Decimation Rate	0x204	16	0xF	No.
Chopper Gate Size	0x21C	32	Read only.	Yes (Already have.)
MPS Current Switch	0x2C8	8	0x03	Yes (Already have.)
MPS Clear	0x2C9	8	0x0	Yes (Already have.)
Timing Protection Switch	0x2CA	8	0x03	Yes
Timing Protection Margin	0x2CB	8	0x80	Yes
Edge Detection Threshold	0x2D8	16	0x1000	Yes
Timing Signal Delay 1	0x2D6	8	0xBB	No. For our use only.
MPS Channel Flag	0x2D0	8	Read only.	Yes (Already have.)

## 11. A Complete Register description

Key Registers			
Register	Add.	Data Width	Description
Digitizer Mode	0x200	8	Use x80. Bit <7> - '1' - External (Sync) arm, '0' - software arm. Bit <6> - '1' - Sample on trigger, '0' - no trigger. Bit <5> - '1' - Use gate, '0' - no gate. Bits <3:2> - Not used. Bit <1> - '1' = Gate controls number of integration windows (with a preset delay at the end, see register 0x2BE). Bit <0> - '1' = CW Mode, constantly running infinite number of windows.
Switch Off	0x201	8	Write '1' to force digitizer to stop.
Software Arm	0x203	8	Set to '1' to arm.
Digitizer Busy	0x2AE	8	Read only. '1' - Busy, '0' - Not busy.
Firmware Version	0x2A8	32	Read only. Shows firmware version.
Block Count	0x218	32	Read only. Number of runs.
A32 Data Pointer	0x04	32	Address offset for corrected data. To access ADC raw data use Data Pointer + x4000 as address.
Channel Buffer Size	0x08	32	Number of 32-bit words reserved for each channel in the memory.
Raw Data Sampling Rate	0x204	16	Bits <15:0> - Hex value is the sampling rate factor. $T_s = T_c * (VALUE + 1)$ , where $T_c = 1/clock\_rate$ .
Number of Raw Samples	0x20C	32	Bits <23:0> - Number of samples or Number of Samples Per Trigger in trigger modes.

Window Size	0x2BA	16	Integration window size (in sample counts) for Baseline Integration. Max value 0x2000 (8192).
Window Size Multiplier	0x2B8	8	Multiply this number with "Window Size" gives you the integration size for Pulse integration. The product of the two cannot exceed 0x8000 (32768).
Number of Windows	0x2BC	16	Unsigned. Sets number of integration windows. Minimum value = 0x1.
Rdbk Current Window No.	0x238	16	Reads back current window count.
After-Gate Delay	0x2BE	16	Unsigned. Number of clock cycles to extend received chopper gate when using gate to control number of integration windows.
Number of Averaged Data Samples	0x2B4	16	Number of samples to save to memory for Averaged Data
Averaged Data Deci. Rate	0x2B7	8	Decimation Rate for averaged data. Decimation rate = $2^{\#}$ .
Raw Data Decimation Rate	0x204	16	Raw data decimation rate = $\# + 1$ .
Sync Delay	0x2C0	16	Delay of # ADC-clock cycles after digitizer receives trigger.
Channel Delay 1	0x3F0	16	Number of clock cycles delayed after digitizer is armed, before integration begins. Channel 1
Channel Delay 2	0x3F2	16	Number of clock cycles delayed after digitizer is armed, before integration begins. Channel 2
Channel Delay 3	0x3F4	16	Number of clock cycles delayed after digitizer is armed, before integration begins. Channel 3
Channel Delay 4	0x3F6	16	Number of clock cycles delayed after digitizer is armed, before integration begins. Channel 4
Channel Delay 5	0x3F8	16	Number of clock cycles delayed after digitizer is armed, before integration begins. Channel 5
Channel Delay 6	0x3FA	16	Number of clock cycles delayed after digitizer is armed, before integration begins. Channel 6
Channel Delay 7	0x3FC	16	Number of clock cycles delayed after digitizer is armed, before integration begins. Channel 7
Channel Delay 8	0x3FE	16	Number of clock cycles delayed after digitizer is armed, before integration begins. Channel 8
Baseline Average Size	0x3C1	8	Size of Baseline Pulse-Over-Pulse Averaging, max 128
Polarity Flip	0x3C2	8	Flip polarity of Intensity reading. Bits <7:0> - Ch8 - 1. '0' - Flip, '1' - Don't flip.
Baseline Correction	0x3C3	8	Bits <7:0> - Ch8 - 1. '1' = ON, '0' = OFF.
Chopper Gate Size	0x21C	32	Length of the "Gate" input. Unit: clock cycles.
Timing Signal Delay 1	0x2D6	8	Delays timing signal to compensate for real time cable delay. Default should be 0xBB.
Timing Signal Delay 2	0x2D7	8	Delays timing signal to compensate for real time cable delay. Default should be 0x0.

**Integration Readout and Threshold Settings are 40 Bits saved in two registers (Signed)**

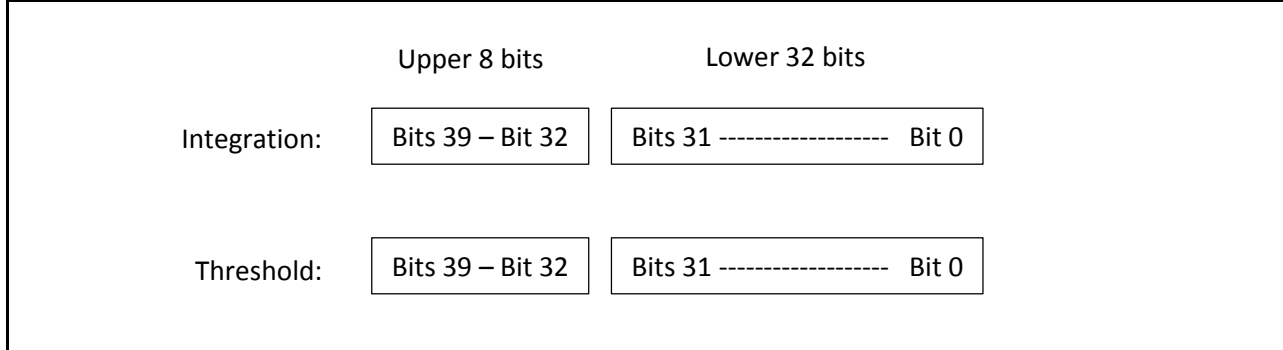

Intensity Readout (Corrected) – Upper 8 Bits		
Register	Add.	Data Width
INT Channel 1	0x318	8
INT Channel 2	0x319	8
INT Channel 3	0x31A	8
INT Channel 4	0x31B	8
INT Channel 5	0x31C	8
INT Channel 6	0x31D	8
INT Channel 7	0x31E	8
INT Channel 8	0x31F	8

Baseline Integration Readout – Upper 8 Bits		
Register	Add.	Data Width
Baseline Channel 1	0x310	8
Baseline Channel 2	0x311	8
Baseline Channel 3	0x312	8
Baseline Channel 4	0x313	8
Baseline Channel 5	0x314	8
Baseline Channel 6	0x315	8
Baseline Channel 7	0x316	8
Baseline Channel 8	0x317	8

Pulse Only Integration Readout – Upper 8 Bits		
Register	Add.	Data Width
Pulse Channel 1	0x308	8
Pulse Channel 2	0x309	8
Pulse Channel 3	0x30A	8
Pulse Channel 4	0x30B	8
Pulse Channel 5	0x30C	8
Pulse Channel 6	0x30D	8
Pulse Channel 7	0x30E	8
Pulse Channel 8	0x30F	8

Intensity Readout (Corrected) – Lower 32 Bits		
Register	Add.	Data Width
INT Channel 1	0x3D0	32
INT Channel 2	0x3D4	32
INT Channel 3	0x3D8	32
INT Channel 4	0x3DC	32
INT Channel 5	0x3E0	32
INT Channel 6	0x3E4	32
INT Channel 7	0x3E8	32
INT Channel 8	0x3EC	32

Pulse Only Integration Readout – Lower 32 Bits		
Register	Add.	Data Width
Pulse Channel 1	0x380	32
Pulse Channel 2	0x384	32
Pulse Channel 3	0x388	32
Pulse Channel 4	0x38C	32
Pulse Channel 5	0x390	32
Pulse Channel 6	0x394	32
Pulse Channel 7	0x398	32
Pulse Channel 8	0x39C	32

Baseline Integration Readout – Lower 32 Bits		
Register	Add.	Data Width
Baseline Channel 1	0x3A0	32
Baseline Channel 2	0x3A4	32
Baseline Channel 3	0x3A8	32
Baseline Channel 4	0x3AC	32
Baseline Channel 5	0x3B0	32
Baseline Channel 6	0x3B4	32
Baseline Channel 7	0x3B8	32
Baseline Channel 8	0x3BC	32

Average Beam Current Readout – All 16 Bits			
Register	Address	Register	Address
Average Beam Current Channel 1	0x298	Average Beam Current Channel 5	0x2A0
Average Beam Current Channel 2	0x29A	Average Beam Current Channel 6	0x2A2
Average Beam Current Channel 3	0x29C	Average Beam Current Channel 7	0x2A4
Average Beam Current Channel 4	0x29E	Average Beam Current Channel 8	0x2A6

Machine Protection Related			
Register	Add.	DW	Description
MPS Switch	0x2C8	8	Bits <7:0> - Switch BLM for channels 7:0, '1'=ON.
MPS Clear	0x2C9	8	Write anything after handling interrupt to reset BLM.
Timing Protection Switch	0x2CA	8	Turning ON/OFF timing check for each channel. Bits 7-0: Channels 8-1. '1' = ON. '0' = OFF.
MPS Force Trip	0x2D5	8	When 0x1, digitizer is forced to trip. Set to 0x0 to reset.
Timing Protection Margin	0x2CB	8	Margin of error allowed when comparing Calculated Pulse Width to Gate Width. Unit: clock cycles.
Edge Detection Threshold	0x2D8	16	Signed 16 bits. Used to compare against ADC raw samples.
MPS Channel Flag	0x2D0	8	Read only. Bits <7:0> - for channels 7:0, '1' = Tripped.
MPS Trip Type	0x2D1	8	Read only. 0x0 = No Trip. 0x1 = Tripped. 0x2 = Timing tripped. 0x3 = Software force tripped.
MPS Tripped Window	0x2D2	16	Records the window number that tripped.
MPS Alarm Frequency	0x2D4	8	BLM alarm (FSD) frequency. $F = F_s / (2 * X)$ . Default 2.
Pulse Direction	0x3C2	8	Pulse direction: '1' = positive, '0' = negative. Bits 7-0: Channels 8-1. For use at PXIE, this bit needs to be '1'.
Calc. Pulse Width Ch1	0x2E8	32	Unsigned. Pulse width calculated from edge detector. Ch 1.
Calc. Pulse Width Ch2	0x2EC	32	Unsigned. Pulse width calculated from edge detector. Ch 2.
Calc. Pulse Width Ch3	0x2F0	32	Unsigned. Pulse width calculated from edge detector. Ch 3.



Calc. Pulse Width Ch4	0x2F4	32	Unsigned. Pulse width calculated from edge detector. Ch 4.
Calc. Pulse Width Ch5	0x2F8	32	Unsigned. Pulse width calculated from edge detector. Ch 5.
Calc. Pulse Width Ch6	0x2FC	32	Unsigned. Pulse width calculated from edge detector. Ch 6.
Calc. Pulse Width Ch7	0x300	32	Unsigned. Pulse width calculated from edge detector. Ch 7.
Calc. Pulse Width Ch8	0x304	32	Unsigned. Pulse width calculated from edge detector. Ch 8.

**Threshold Settings are 40 Bits saved in two registers (Signed)**

Upper 8 bits                      Lower 32 bits

Threshold:    Bits 39 – Bit 32    Bits 31 ----- Bit 0

Note: These thresholds only needed 16 bits for “Average Current” comparison, though I kept 40 bits.

Machine Protection Thresholds – Upper 8 Bits		
Register	Add.	D. Width
Upper Threshold Ch1	0x360	8
Upper Threshold Ch2	0x361	8
Upper Threshold Ch3	0x362	8
Upper Threshold Ch4	0x363	8
Upper Threshold Ch5	0x364	8
Upper Threshold Ch6	0x365	8
Upper Threshold Ch7	0x366	8
Upper Threshold Ch8	0x367	8

Machine Protection Thresholds - Upper 8 Bits		
Register	Add.	D. Width
Lower Threshold Ch1	0x368	8
Lower Threshold Ch2	0x369	8
Lower Threshold Ch3	0x36A	8
Lower Threshold Ch4	0x36B	8
Lower Threshold Ch5	0x36C	8
Lower Threshold Ch6	0x36D	8
Lower Threshold Ch7	0x36E	8
Lower Threshold Ch8	0x36F	8

Machine Protection Thresholds – Lower 32 Bits		
Register	Add.	D. Width
Upper Threshold Ch1	0x320	32
Upper Threshold Ch2	0x324	32
Upper Threshold Ch3	0x328	32
Upper Threshold Ch4	0x32C	32
Upper Threshold Ch5	0x330	32
Upper Threshold Ch6	0x334	32
Upper Threshold Ch7	0x338	32
Upper Threshold Ch8	0x33C	32

Machine Protection – Lower 32 Bits		
Register	Add.	D. Width
Lower Threshold Ch1	0x340	32
Lower Threshold Ch2	0x344	32
Lower Threshold Ch3	0x348	32
Lower Threshold Ch4	0x34C	32
Lower Threshold Ch5	0x350	32
Lower Threshold Ch6	0x354	32
Lower Threshold Ch7	0x358	32
Lower Threshold Ch8	0x35C	32

Note: the following registers are not commonly used and do not need to be touched unless a specific configuration is required.

VME Interface Registers			
Register	Add.	D. Width	Description
Channel Mask	0x00	8	Bits <7:0> - Set masks for Ch8 to Ch1 respectively. Bit <7> for Ch8, Bit <0> for Ch1. "1" = ON, "0" = OFF. Example: "00000001" means only Ch1 active.
DCDC Mode	0x01	8	Bits <1,0> - "00" – Fixed frequency, "01" – sweep 10% frequency, "1X" – spread spectrum. Default = "00".
VME IRQ Interrupt Level	0x02	8	Bits <2:0> - Hex number indicates the VME IRQ line. "000" = No interrupt "001" = IRQ1, "002" = IRQ2, ...
VME A32 Pointer for ADC Raw Data	0x04	32	Indicates the starting address in memory for ADC raw data.
Channel Buffer Size for Raw Data	0x08	32	Indicates number of 32-bit words (two samples in each word) in memory reserved for each channel.
VME A24 Pointer for FPGA Flash Config. Data	0x24	32	
Buffer Size for FPGA Flash Config. Data	0x28	32	Indicates number of 32-bit words (two samples in each word) in memory reserved for each channel.
VME A24 Pointer for Digitizer Flash Settings Data	0x2C	32	
Buffer Size for Digitizer Flash Settings Data	0x30	32	Indicates number of 32-bit words (two samples in each word) in memory reserved for each channel.
VME A24 Pointer for Digitizer Flash Data	0x34	32	
Buffer Size for Digitizer Flash Data	0x38	32	Indicates number of 32-bit words (two samples in each word) in memory reserved for each channel.
Board ID (Read Only)	0x3C	32	Board ID, read only.
Generic Register 0	0x60	32	Available for software user.
Generic Register 1	0x64	32	Available for software user.
Generic Register 2	0x68	32	Available for software user.
Generic Register 3	0x6C	32	Available for software user.
Generic Register 4	0x70	32	Available for software user.
Generic Register 5	0x74	32	Available for software user.
Generic Register 6	0x78	32	Available for software user.
Generic Register 7	0x7C	32	Available for software user.

Interrupt			
Register	Add.	Data Width	Description
Software Set IRQ, #0 ~ #15	0x206	16	Bits <15:0> - IRQ15 ~ IRQ0. IRQ15 ~ IRQ12 not used in this design. Generate software interrupts by writing into register. Read back to see non-masked active interrupts (software or hardware generated).
VME IRQ Mask	0x290	16	Bits <11:0> - Mask for IRQ11 ~ IRQ0. "1" = Active, "0" = Disabled
IRQ Vector for IRQ #0	0x220	16	Active when ADC data out of range (any channel).
IRQ Vector for IRQ #1	0x222	16	Data available to read at the end of window.
IRQ Vector for IRQ #2	0x224	16	Machine Protection System Tripped.
IRQ Vector for IRQ #3	0x226	16	Active at end of WB Gate #2
IRQ Vector for IRQ #4	0x228	16	Active at end of WB Gate #3
IRQ Vector for IRQ #5	0x22A	16	Active at end of WB Gate #4
IRQ Vector for IRQ #6	0x22C	16	Active at end of WB Gate #5
IRQ Vector for IRQ #7	0x22E	16	Active at end of WB Gate #6
IRQ Vector for IRQ #8	0x230	16	Active at end of WB Gate #7
IRQ Vector for IRQ #9	0x232	16	Active at end of NB Gate
IRQ Vector for IRQ #10	0x234	16	Active at start of digitizer mode
IRQ Vector for IRQ #11	0x236	16	Active at end of digitizer mode

SYNC Module Control Registers			
Register	Add.	Data Width	Description
Time Stamp Counter, Sync with TCLK Events	0x100	16	Bits <15:0> - Read back of time stamp counter. (Read Only)
TCLK Start Delay	0x102	16	Bits <15:0> - TCLK Start Delay.
TCLK Stop Delay	0x104	16	Bits <15:0> - TCLK Stop Delay.
TCLK Delay Scale	0x106	16	Bits <15:0> - TCLK Delay Scale.
BSYNC Start Delay	0x108	16	Bits <15:0> - BSYNC Start Delay.
BSYINC Stop Delay	0x10A	16	Bits <15:0> - BSYNC Stop Delay.
BSYNC Delay Scale	0x10C	16	Bits <15:0> - BSYNC Delay Scale.
TCLK Start Event	0x10E	8	Bits <7:0> - TCLK Start Event.
TCLK Stop Event	0x10F	8	Bits <7:0> - TCLK Stop Event.
BSYNC Start Event	0x110	8	Bits <7:0> - BSYNC Start Event.
BSYNC Stop Event	0x111	8	Bits <7:0> - BSYNC Stop Event.
SYNC In Source Mode	0x112	8	Bits <7:0> - Source for SYNC In signal on ATF. "0x0" = External Sync Signal, "0x1" = TCLK Start Event, "0x2" = TCLK Stop Event, "0x3" = BSYNC Start Event,

			"0x4" = BSYNC Stop Event.
Trigger Source Mode	0x113	8	Bits <7:0> - Source for Trigger signal on ATF. "0x0" = External Trigger Signal, "0x1" = TCLK Start Event, "0x2" = TCLK Stop Event, "0x3" = BSYNC Start Event, "0x4" = BSYNC Stop Event.
Gate Source Mode	0x114	8	Bits <7:0> - Source for Gate signal on ATF. "0x0" = External Gate Signal, "0x1" = TCLK Start/Stop Event, "0x2" = BSYNC Start/Stop Event.
SYNC Out Source Mode	0x115	8	Bits <7:0> - Source for Sync Out port. "0x0" = External Sync In, "0x1" = External Trigger, "0x2" = External Gate, "0x3" = TCLK Start Event, "0x4" = TCLK Stop Event, "0x5" = BSYNC Start Event, "0x6" = BSYNC Stop Event, "0x7" = ADC samples, "0x8" = Mode Active, "0x9" = ADC's clock, "0xA" = ATF-NB gate, "0xB" = ATF-WB gates, "0xC" = TBT gate, "0xD" = Turn Marker.

Sync IRQ			
Register	Add.	Data Width	Description
SYNC IRQ Mask	0x118	16	Bits <8:0> - Mask for SYNC IRQ8 ~ IRQ0. "1" = Active, "0" = Disabled
Software Set SYNC IRQ #0 ~ IRQ #15	0x11A	16	Bits <15:0> - SYNC IRQ15 ~ IRQ0. IRQ15 ~ IRQ9 not used in this design. Generate software interrupts by writing into register. Read back to see non-masked active interrupts (software or hardware generated).
IRQ Vector for IRQ #0	0x120	16	Active on external Sync Signal.
IRQ Vector for IRQ #1	0x122	16	Active on external Trigger signal.
IRQ Vector for IRQ #2	0x124	16	Active on external Gate signal positive edge.
IRQ Vector for IRQ #3	0x126	16	Active on external Gate signal negative edge.
IRQ Vector for IRQ #4	0x128	16	Active on TCLK Start event.
IRQ Vector for IRQ #5	0x12A	16	Active on TCLK Stop event.
IRQ Vector for IRQ #6	0x12C	16	Active on BSYNC Start event.
IRQ Vector for IRQ #7	0x12E	16	Active on BSYNC Stop event.
IRQ Vector for IRQ #8	0x130	16	Active on TCLK time stamp counter reset.

**ADC Chip 1 ADS6445 Registers (All registers are 11 bits – D16)**

Register	Addr.	Default	Description
Power Down Modes Reg. A	0x80	0x00	<p>Bits &lt;9:6&gt; - Not Used. Must be "0".</p> <p>Bit &lt;10&gt; - Software Reset. "1" resets all internal registers and self-clears to "0".</p> <p>Bit &lt;5&gt; - Reference. "0"=Internal Reference Enabled, "1"=External Reference Enabled.</p> <p>Bits &lt;4:1&gt; - Channels 4~1 Power Down. "1"=Power Down, "0"=Normal Operation.</p> <p>Bit &lt;0&gt; - Global Power Down, including channels 1~4. "1"=Power Down, "0"=Normal Operation.</p>
Input Clock Gain Reg. B	0x82	0x00	<p>Bits &lt;10:7, 1:0&gt; - Not Used. Must be "0".</p> <p>Bits &lt;6:2&gt; - CLKIN Gain.</p> <p>"11000" Gain 0, minimum gain</p> <p>"00000" Gain 1, default gain after reset</p> <p>"01100" Gain 2</p> <p>"01010" Gain 3</p> <p>"01001" Gain 4</p> <p>"01000" Gain 5, maximum gain</p>
Capture Test Pattern Reg. C	0x84	0x200	<p>Bits &lt;10, 8, 4:0&gt; - Not Used. Must be "0".</p> <p>Bit &lt;9&gt; - Data Format Selection.</p> <p>"0" = 2's Complement format</p> <p>"1" = Straight binary format</p> <p>Bits &lt;7:5&gt; - Capture Test Patterns.</p> <p>000 Normal ADC operation</p> <p>001 Output all zeros</p> <p>010 Output all ones</p> <p>011 Output toggle pattern</p> <p>100 Unused</p> <p>101 Output custom pattern (contents of CUSTOM pattern registers 0x86 and 0x88)</p> <p>110 Output DESKEW pattern (serial stream of 1010...)</p> <p>111 Output SYNC pattern</p>
Test Patterns Reg. D	0x86	0xAA	<p>Bits &lt;10:0&gt; - Lower 11 bits of custom pattern.</p> <p>D10 D9 D8 ... D0</p>
Fine Gain Reg. E	0x88	0x02	<p>Bits &lt;2:0&gt; - Upper 3 bits of custom pattern.</p> <p>D13 D12 D11</p> <p>Bits &lt;7:3&gt; - Not Used. Must be "0".</p> <p>Bits &lt;10:8&gt; - Fine Gain Control.</p> <p>000 0dB Gain (full-scale range=2.00VPP)</p> <p>001 1dB Gain (full-scale range=1.78VPP)</p> <p>010 2dB Gain (full-scale range=1.59VPP)</p> <p>011 3dB Gain (full-scale range=1.42VPP)</p>

			<p>100 4dB Gain (full-scale range=1.26VPP)  101 5dB Gain (full-scale range=1.12VPP)  110 6dB Gain (full-scale range=1.00VPP)</p>
Output Data Config. Reg. F	0x8A	0x00	<p>Bit &lt;10&gt; - Over-Ride Bit. All the functions in this register can also be controlled using the parallel control pins. By setting this bit to "1", the contents of register will over-ride the settings of the parallel pins.  Bits &lt;9:8, 3&gt; - Not Used. Must be "0".  Bit &lt;7&gt; - Byte/bit Wise outputs.  "0": Byte wise, "1": bit wise.  Bit &lt;6&gt; - MSB or LSB First Selection.  "0": MSB First, "1": LSB First.  Bit &lt;5&gt; - Coarse Gain Control.  "0"=0dB Coarse Gain (full-scale range=2.0 VPP),  "1"=3.5dB Coarse Gain (full-scale range=1.34 VPP)  Bit &lt;4&gt; - Bit Clock Capture Edge (only when SDR bit clock is selected, Bit 1 = "1").  "0"=Capture data with falling edge of bit clock,  "1"=Capture data with rising edge of bit clock.  Bit &lt;2&gt; - Serialization Factor Selection. "0"=14x Serialization, "1"=16x Serialization.  Bit &lt;1&gt; - Bit Clock Selection (only in 2-wire interface). "0"=DDR Bit Clock, "1"=SDR Bit Clock.  Bit &lt;0&gt; - Interface Selection. "0"=1 Wire interface, "1"=2 Wire interface.</p>
Data Interface Reg. G	0x8C	0x140	<p>Bit &lt;0&gt; - LVDS Current Double For Data Outputs.  "0"=Nominal LVDS current, as set by Bits &lt;5:2&gt;.  "1"=Double the nominal value.  Bit &lt;1&gt; - LVDS Current Double for Bit and Word Clock Outputs.  "0"=Nominal LVDS current, as set by Bits&lt;5:2&gt;.  "1"=Double the nominal value.  Bits &lt;3:2&gt; - LVDS Current Setting for Data Outputs.  00 3.5mA  01 4mA  10 2.5mA  11 3mA  Bits &lt;5:4&gt; - CVDS Current Setting For Bit and Word Clock Outputs.  00 3.5mA  01 4mA  10 2.5mA  11 3mA  Bits &lt;10:6&gt; - LVDS Internal Termination For Bit and Word Clock outputs.  "00000" No internal termination</p>

			<p>“00001” 166 Ω  “00010” 200 Ω  “00100” 250 Ω  “01000” 333 Ω  “10000” 500 Ω</p> <p>Any combination of above bits can be programmed, resulting in a parallel combination of the selected values. For example, “00101” is the parallel combination of 166   250=100 Ω  “00101” 100 Ω</p>
Data Interface Reg. H	0x8E	0x05	<p>Bits &lt;10:9&gt; - Only when 2-wire interface is selected.  “00” Byte-wise or bitwise output, 1x frame clock  “11” Word-wise output enabled, 0.5x frame clock  Bits &lt;8:5&gt; - Not Used. Must be “0”.  Bits &lt;4:0&gt; - LVDS Internal Termination For Data Outputs.</p> <p>“00000” No internal termination  “00001” 166 Ω  “00010” 200 Ω  “00100” 250 Ω  “01000” 333 Ω  “10000” 500 Ω</p> <p>Any combination of above bits can be programmed, resulting in a parallel combination of the selected values. For example, “00101” is the parallel combination of 166   250=100 Ω  “00101” 100 Ω</p>

ADC Chip 2 ADS6445 Registers (All registers are 11 bits – D16)			
Register	Addr.	Default	Description
Power Down Modes Reg. A	0x90	0x00	<p>Bits &lt;9:6&gt; - Not Used. Must be “0”.  Bit &lt;10&gt; - Software Reset. “1” resets all internal registers and self-clears to “0”.  Bit &lt;5&gt; - Reference. “0”=Internal Reference Enabled, “1”=External Reference Enabled.  Bits &lt;4:1&gt; - Channels 8~5 Power Down. “1”=Power Down, “0”=Normal Operation.  Bit &lt;0&gt; - Global Power Down, including channels 5~8. “1”=Power Down, “0”=Normal Operation.</p>
Input Clock Gain Reg. B	0x92	0x00	<p>Bits &lt;10:7, 1:0&gt; - Not Used. Must be “0”.  Bits &lt;6:2&gt; - CLKIN Gain.</p> <p>“11000” Gain 0, minimum gain  “00000” Gain 1, default gain after reset  “01100” Gain 2  “01010” Gain 3</p>

			<p>"01001" Gain 4</p> <p>"01000" Gain 5, maximum gain</p>
Capture Test Pattern Reg. C	0x94	0x200	<p>Bits &lt;10, 8, 4:0&gt; - Not Used. Must be "0".</p> <p>Bit &lt;9&gt; - Data Format Selection.</p> <p>"0" = 2's Complement format</p> <p>"1" = Straight binary format</p> <p>ts &lt;7:5&gt; - Capture Test Patterns.</p> <p>000 Normal ADC operation</p> <p>001 Output all zeros</p> <p>010 Output all ones</p> <p>011 Output toggle pattern</p> <p>100 Unused</p> <p>101 Output custom pattern (contents of CUSTOM pattern registers 0x86 and 0x88)</p> <p>110 Output DESKEW pattern (serial stream of 1010...)</p> <p>111 Output SYNC pattern</p>
Test Patterns Reg. D	0x96	0xAA	<p>Bits &lt;10:0&gt; - Lower 11 bits of custom pattern.</p> <p>D10 D9 D8 ... D0</p>
Fine Gain Reg. E	0x98	0x02	<p>Bits &lt;2:0&gt; - Upper 3 bits of custom pattern.</p> <p>D13 D12 D11</p> <p>Bits &lt;7:3&gt; - Not Used. Must be "0".</p> <p>Bits &lt;10:8&gt; - Fine Gain Control.</p> <p>000 0dB Gain (full-scale range=2.00VPP)</p> <p>001 1dB Gain (full-scale range=1.78VPP)</p> <p>010 2dB Gain (full-scale range=1.59VPP)</p> <p>011 3dB Gain (full-scale range=1.42VPP)</p> <p>100 4dB Gain (full-scale range=1.26VPP)</p> <p>101 5dB Gain (full-scale range=1.12VPP)</p> <p>110 6dB Gain (full-scale range=1.00VPP)</p>
Output Data Config. Reg. F	0x9A	0x00	<p>Bit &lt;10&gt; - Over-Ride Bit. All the functions in this register can also be controlled using the parallel control pins. By setting this bit to "1", the contents of register will over-ride the settings of the parallel pins.</p> <p>Bits &lt;9:8, 3&gt; - Not Used. Must be "0".</p> <p>Bit &lt;7&gt; - Byte/bit Wise outputs.</p> <p>"0": Byte wise, "1": bit wise.</p> <p>Bit &lt;6&gt; - MSB or LSB First Selection.</p> <p>"0": MSB First, "1": LSB First.</p> <p>Bit &lt;5&gt; - Coarse Gain Control.</p> <p>"0"=0dB Coarse Gain (full-scale range=2.0 VPP),</p> <p>"1"=3.5dB Coarse Gain (full-scale range=1.34 VPP)</p> <p>Bit &lt;4&gt; - Bit Clock Capture Edge (only when SDR bit clock is selected, Bit 1 = "1").</p> <p>"0"=Capture data with falling edge of bit clock,</p> <p>"1"=Capture data with rising edge of bit clock.</p>



			<p>Bit &lt;2&gt; - Serialization Factor Selection. "0"=14x Serialization, "1"=16x Serialization.</p> <p>Bit &lt;1&gt; - Bit Clock Selection (only in 2-wire interface). "0"=DDR Bit Clock, "1"=SDR Bit Clock.</p> <p>Bit &lt;0&gt; - Interface Selection. "0"=1 Wire interface, "1"=2 Wire interface.</p>
Data Interface Reg. G	0x9C	0x140	<p>Bit &lt;0&gt; - LVDS Current Double For Data Outputs. "0"=Nominal LVDS current, as set by Bits &lt;5:2&gt;. "1"=Double the nominal value.</p> <p>Bit &lt;1&gt; - LVDS Current Double for Bit and Word Clock Outputs. "0"=Nominal LVDS current, as set by Bits&lt;5:2&gt;. "1"=Double the nominal value.</p> <p>Bits &lt;3:2&gt; - LVDS Current Setting for Data Outputs.</p> <p>00 3.5mA 01 4mA 10 2.5mA 11 3mA</p> <p>Bits &lt;5:4&gt; - CVDS Current Setting For Bit and Word Clock Outputs.</p> <p>00 3.5mA 01 4mA 10 2.5mA 11 3mA</p> <p>Bits &lt;10:6&gt; - LVDS Internal Termination For Bit and Word Clock outputs.</p> <p>"00000" No internal termination "00001" 166 Ω "00010" 200 Ω "00100" 250 Ω "01000" 333 Ω "10000" 500 Ω</p> <p>Any combination of above bits can be programmed, resulting in a parallel combination of the selected values. For example, "00101" is the parallel combination of 166    250=100 Ω "00101" 100 Ω</p>
Data Interface Reg. H	0x9E	0x05	<p>Bits &lt;10:9&gt; - Only when 2-wire interface is selected. "00" Byte-wise or bitwise output, 1x frame clock "11" Word-wise output enabled, 0.5x frame clock</p> <p>Bits &lt;8:5&gt; - Not Used. Must be "0".</p> <p>Bits &lt;4:0&gt; - LVDS Internal Termination For Data Outputs.</p> <p>"00000" No internal termination "00001" 166 Ω "00010" 200 Ω "00100" 250 Ω</p>

			<p>“01000” 333 Ω</p> <p>“10000” 500 Ω</p> <p>Any combination of above bits can be programmed, resulting in a parallel combination of the selected values. For example, “00101” is the parallel combination of 166   250=100 Ω</p> <p>“00101” 100 Ω</p>
--	--	--	--

ADC Overflow			
Register	Add.	Data Width	Description
ADC's OVR Status	0x2AD	8	Bits <7:0> - Denotes ADC data saturation for channels 8 to 1. Example: Bit <7> = Ch8. “1” = Overflow, “0” = Normal.
ADC 1 Abs Max Count	0x370	16	ADC data max count recorder for channel 1.
ADC 2 Abs Max Count	0x372	16	ADC data max count recorder for channel 2.
ADC 3 Abs Max Count	0x374	16	ADC data max count recorder for channel 3.
ADC 4 Abs Max Count	0x376	16	ADC data max count recorder for channel 4.
ADC 5 Abs Max Count	0x378	16	ADC data max count recorder for channel 5.
ADC 6 Abs Max Count	0x37A	16	ADC data max count recorder for channel 6.
ADC 7 Abs Max Count	0x37C	16	ADC data max count recorder for channel 7.
ADC 8 Abs Max Count	0x37E	16	ADC data max count recorder for channel 8.

ADC Delays			
Register	Add.	Data Width	Description
ADC 1 Data Delay	0x140	8	Bits <4:0> - Data delay for channel 1, in ADC samples. Ranges from “0” to “31”. Default is 16.
ADC 2 Data Delay	0x141	8	Bits <4:0> - Data delay for channel 2, in ADC samples. Ranges from “0” to “31”. Default is 16.
ADC 3 Data Delay	0x142	8	Bits <4:0> - Data delay for channel 3, in ADC samples. Ranges from “0” to “31”. Default is 16.
ADC 4 Data Delay	0x143	8	Bits <4:0> - Data delay for channel 4, in ADC samples. Ranges from “0” to “31”. Default is 16.
ADC 5 Data Delay	0x144	8	Bits <4:0> - Data delay for channel 5, in ADC samples. Ranges from “0” to “31”. Default is 16.
ADC 6 Data Delay	0x145	8	Bits <4:0> - Data delay for channel 6, in ADC samples. Ranges from “0” to “31”. Default is 16.
ADC 7 Data Delay	0x146	8	Bits <4:0> - Data delay for channel 7, in ADC samples. Ranges from “0” to “31”. Default is 16.
ADC 8 Data Delay	0x147	8	Bits <4:0> - Data delay for channel 8, in ADC samples. Ranges from “0” to “31”. Default is 16.

Clock Driver			
Register	Addr.	Data Width	Description
Control Register 0 (Output Divider 0)	0xA0	32	<p>Bits &lt;0:1&gt; - Pre-Divider selection for primary reference. "00" = 3-state, "01" = divide by 1, "10", divide by 2, "11" = reserved.</p> <p>Bits &lt;4:5&gt; - Output Mux 0 Select. "00" = PRI_IN (On board oscillator), "01" = SEC_IN (External clock), "10" = SMART_MUX, "11" = VCO_CORE.</p> <p>Bits &lt;12:6&gt; - Coarse phase adjust select for output 0. Bits &lt;19:13&gt; - Output Divider 0 Ratio Select. Bit &lt;20&gt; - "1" = output 0 enabled, "0" = disabled.</p> <p>Bit &lt;21&gt; - High swing LVPEC when set to "1", normal swing when set to "0". Bits &lt;3:2&gt; - Reserved. Bits &lt;26:27&gt; - Output buffer select 0.</p> <p>Bits &lt;22:23&gt; - LVCMOS mode select for Output 0 positive pin. "00" = Active, "10" = Inverting, "11" = Low, "01" = 3-state.</p> <p>Bits &lt;24:25&gt; - LVCMOS mode select for Output 0 negative pin. "00" = Active, "10" = Inverting, "11" = Low, "01" = 3-state.</p>
Control Register 1 (Output Divider 1)	0xA4	32	<p>Bits &lt;0:1&gt; - Pre-Divider selection for secondary reference. "00" = 3-state, "01" = divide by 1, "10", divide by 2, "11" = reserved.</p> <p>Bits &lt;4:5&gt; - Output Mux 1 Select. "00" = PRI_IN (On board oscillator), "01" = SEC_IN (External clock), "10" = SMART_MUX, "11" = VCO_CORE.</p> <p>Bits &lt;12:6&gt; - Coarse phase adjust select for output 1. Bits &lt;19:13&gt; - Output Divider 1 Ratio Select. Bit &lt;20&gt; - "1" = output 1 enabled, "0" = disabled.</p> <p>Bit &lt;21&gt; - High swing LVPEC when set to "1", normal swing when set to "0". Bits &lt;3:2&gt; - Reserved. Bits &lt;26:27&gt; - Output buffer select 1.</p> <p>Bits &lt;22:23&gt; - LVCMOS mode select for Output 1 positive pin. "00" = Active, "10" = Inverting, "11" = Low, "01" = 3-state.</p> <p>Bits &lt;24:25&gt; - LVCMOS mode select for Output 1 negative pin. "00" = Active, "10" = Inverting, "11" = Low, "01" = 3-state.</p>
Control Register 2 (Output Divider 2)	0xA8	32	<p>Bit&lt;0&gt; - Reference divider bit 0. Bit&lt;1&gt; - Reference divider bit 1. Bits &lt;3:2&gt; - Reserved. Bits &lt;26:27&gt; - Output buffer select 2.</p> <p>Bits &lt;4:5&gt; - Output Mux 2 Select. "00" = PRI_IN (On board oscillator), "01" = SEC_IN (External clock), "10" = SMART_MUX, "11" = VCO_CORE.</p>

			<p>Bits &lt;12:6&gt; - Coarse phase adjust select for output 2. Bits &lt;19:13&gt; - Output Divider 2 Ratio Select. Bit &lt;20&gt; - "1" = output 2 enabled, "0" = disabled.</p> <p>Bit &lt;21&gt; - High swing LVPEC when set to "1", normal swing when set to "0".</p> <p>Bits &lt;22:23&gt; - LVCMOS mode select for Output 2 positive pin. "00" = Active, "10" = Inverting, "11" = Low, "01" = 3-state.</p> <p>Bits &lt;24:25&gt; - LVCMOS mode select for Output 2 negative pin. "00" = Active, "10" = Inverting, "11" = Low, "01" = 3-state.</p>
Control Register 3 (Output Divider 3)	0xAC	32	<p>Bit&lt;0&gt; - Reference divider bit 2. Bits &lt;3:1&gt; - Reserved. Bits &lt;26:27&gt; - Output buffer select 3.</p> <p>Bits &lt;4:5&gt; - Output Mux 3 Select. "00" = PRI_IN (On board oscillator), "01" = SEC_IN (External clock), "10" = SMART_MUX, "11" = VCO_CORE.</p> <p>Bits &lt;12:6&gt; - Coarse phase adjust select for output 3. Bits &lt;19:13&gt; - Output Divider 3 Ratio Select. Bit &lt;20&gt; - "1" = output 3 enabled, "0" = disabled.</p> <p>Bit &lt;21&gt; - High swing LVPEC when set to "1", normal swing when set to "0".</p> <p>Bits &lt;22:23&gt; - LVCMOS mode select for Output 3 positive pin. "00" = Active, "10" = Inverting, "11" = Low, "01" = 3-state.</p> <p>Bits &lt;24:25&gt; - LVCMOS mode select for Output 3 negative pin. "00" = Active, "10" = Inverting, "11" = Low, "01" = 3-state.</p>
Control Register 4 (Output Divider 4)	0xB0	32	<p>Bit&lt;0&gt; - Reserved, must be set to "1". Bits &lt;3:1&gt; - Reserved.</p> <p>Bits &lt;4:5&gt; - Output Mux 4 Select. "00" = PRI_IN (On board oscillator), "01" = SEC_IN (External clock), "10" = SMART_MUX, "11" = VCO_CORE.</p> <p>Bits &lt;12:6&gt; - Coarse phase adjust select for output 4. Bits &lt;19:13&gt; - Output Divider 4 Ratio Select. Bit &lt;20&gt; - "1" = output 4 enabled, "0" = disabled.</p> <p>Bit &lt;21&gt; - High swing LVPEC when set to "1", normal swing when set to "0". Bits &lt;26:27&gt; - Output buffer select 4.</p> <p>Bits &lt;22:23&gt; - LVCMOS mode select for Output 4 positive pin. "00" = Active, "10" = Inverting, "11" = Low, "01" = 3-state.</p> <p>Bits &lt;24:25&gt; - LVCMOS mode select for Output 4 negative pin. "00" = Active, "10" = Inverting, "11" = Low, "01" = 3-state.</p>
Control Register 5	0xB4	32	<p>Bits &lt;0:1&gt; - Input buffer select. "01" = LVPECL, "11" = LVDS, "00" = LVCMOS. Bits &lt;2:4&gt; - EEPROM clock select. Bit &lt;5&gt; - EEPROM clock select enable.</p>

			<p>Bit &lt;6&gt; - Input buffer termination. "1" = DC, "0" = AC. Bit &lt;7&gt; - Input buffers hysteresis enable, "1" recommended.</p> <p>Bit &lt;8&gt; - Primary input termination. "0" = enable, "1" = disable. Bit &lt;9&gt; - Primary input negative pin biased with internal Vbb voltage when set to "1".</p> <p>Bit &lt;10&gt; - Secondary input negative pin biased with internal Vbb voltage when set to "1". Bits &lt;13:12&gt; - Reserved, must be "0".</p> <p>Bit &lt;11&gt; - Fail Safe is enabled for all input buffers when set to "1", DC coupling only. Bits &lt;21:14&gt; - Input Divider settings.</p> <p>Bits &lt;25:22&gt; - Lock-detect window width. "0000" = Narrow window, "0001", "0010", "0100", "0101", ... "1110" = Widest window, "XX11" = Reserved.</p> <p>Bit &lt;26&gt; - "0" = triggers after first lock detection, "1" = triggers after 64 cycles of lock detection.</p> <p>Bit &lt;27&gt; - "0" selects digital PLL Lock 0, "1" selects digital PLL Lock 1.</p>
Control Register 6	0xB8	32	<p>Bit &lt;0&gt; - VCO select, "0": VCO1 (low range), "1": VCO2 (high range). Bits &lt;2:1&gt; - Pre-scaler setting. Bits &lt;23, 11&gt; - Reserved, must be set to "0".</p> <p>Bits &lt;15:13&gt; - Bypass Divider setting. Bits &lt;10:3&gt; - Feedback Divider setting. Bit &lt;26&gt; - "1" = External loop filter is used, "0" = Internal loop filter is used.</p> <p>Bit &lt;12&gt; - "0" = Secondary input buffer internal termination enabled, "1" = Secondary internal termination circuitry disabled.</p> <p>Bit &lt;20&gt; - "0" = outputs synchronized to reference input on low-to-high pulse on SYNC pin, "1" = outputs synchronized to SYNC high-to-low pulse.</p> <p>Bit &lt;21&gt; - "1" = Wide pulse, "0" = Narrow pulse. Bit &lt;22&gt; - Enable VCO calibration command. Bit &lt;24&gt; - Enable auxiliary output when set to "1".</p> <p>Bit &lt;25&gt; - Select the output that will drive AUX output. "0" = Output divider 2, "1" = divider 3.</p> <p>Bit &lt;27&gt; - "1": Calibration mode = Manual mode, "0": Calibration mode = startup mode. Bits &lt;19:16&gt; - Charge Pump current select.</p>
Control Register 7	0xBC	32	<p>Bits &lt;20:0&gt; - Loop filter control setting. Bit &lt;21&gt; - Reserved, must be set to "0". Bits &lt;24, 22&gt; - Diagnostics, set to "1".</p> <p>Bits &lt;25, 23&gt; - Smart Mux. "0" enables short delay for fast operation, "1" for long delay. Bit &lt;26&gt; - Read only. "0" = EEPROM unlock. "1" = EEPROM locked.</p> <p>Bit &lt;27&gt; - Reserved, always reads "1".</p>

Control Register 8	0xC0	32	Bits <5:0> - Calibration read back from device. Bit <6> - Read only, status of the PLL lock pin driven by the device. Bit <7> - "0" = Set device Sleep mode ON, "1" = Normal mode. Bit <8> - "0" = Forces /SYNC, "1" = exit Sync. Bits <20, 13, 9> - Reserved, must be set to "0". Bits <12:10> - Silicon Revision. Bits <24:21, 19:14> - Factor registers. Bits <27:24> - Synthesizer Source Indicator.
Unlock CDCE62005	0xC4	8	Write Only. Bit <0> - Unlock CDCE62005.
Lock CDCE62005	0xC5	8	Write Only. Bit <0> - Copy data from RAM to EEPROM. Use discouraged.
Oscillator Enable	0xC6	8	Bit <0> - "1" – Enable internal oscillator for ADC clock.
Clock Reference Select	0xC7	8	Bit <0> - By pin, optional to SPI
Clock Base SYNC	0xC8	8	Bit <0> - By pin, optional to SPI
Clock Base Power Down	0xC9	8	Bit <0> - By pin, optional to SPI
Clock Base PLL Lock	0xCA	8	Bit <0> - "1" – PLL locked.

Flash			
Register	Addr.	Data Width	Description
Write Enable	0x160	8	Write command to enable write ops to Flash.
Write Disable	0x161	8	Write command to disable write ops to Flash.
Read/Write Status	0x162	8	Read/Write to Flash status register.
Erase Bulk	0x163	8	Write command to erase bulk in Flash.
Read Flash Chip ID	0x164	8	Read Flash ID.
Erase Sector	0x168	32	Write command to erase sector of Flash. Bits <23:0> - Number of sectors.

Remote Update			
Register	Address	Data Width	Description
Read Master State Machine (MSM) Current State Mode	0x180	8	NA
Read Past Status 1 MSM Mode	0x181	8	NA
Read Current Application Mode Watch Dog Enable	0x182	8	NA
Read Past Status 1 Reconfiguration Trigger Conditions Source	0x183	8	NA
Read Past Status 2 MSM Mode	0x184	8	NA
Read Past Status 2 Reconfiguration Trigger Conditions Source	0x185	8	NA

R/W the Early Conf_Done Check	0x186	8	NA
R/W Watchdog Enable Value	0x187	8	NA
R/W The Osc_Internal Option	0x188	8	NA
R/W Watchdog Timeout Value	0x18A	16	NA
Read Current Application Mode Watchdog Time Value	0x18C	32	NA
Read Past Status 1 Boot Address	0x190	32	NA
Read Past Status 2 Boot Address	0x194	32	NA
R/W Boot Address (Upper 22 bits of 24 bit address value)	0x198	32	NA
Read Current Factory Mode Boot Address 24 bit	0x19C	32	NA
Write the Command to Reconfigure FPGA	0x1A0	8	NA
Write the Command to Reset Watchdog Timer	0x1A6	8	NA

## 12. Connectors and Switches

